

取料机链

Feed Taking Machine Chains

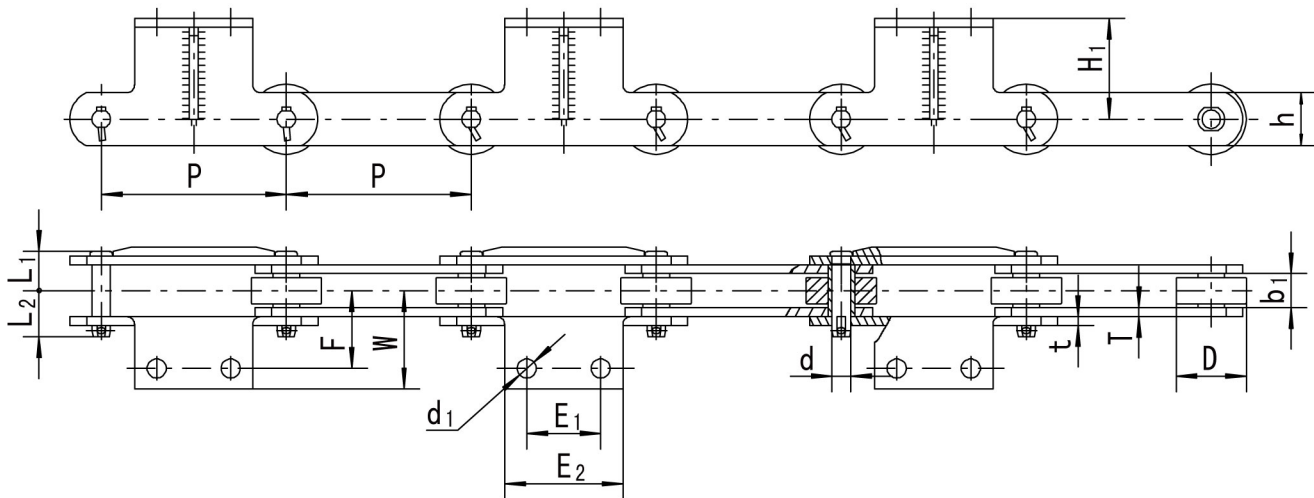

链号 Chain No.	E <sub>1</sub>	E <sub>2</sub>	F	W	d <sub>1</sub>	H <sub>1</sub>
SPN250A-SK <sub>2</sub> -2P	100	160	106	134.1	26	136
SPN250B-SK <sub>2</sub> -2P	100	152	83	112	21	150
SPN315A-SK <sub>2</sub> -2P	130	190	89.5	125.5	21	140

链号 Chain No.	节距 Pitch P mm	内节内宽 Width between inner Sidebars b <sub>1</sub> (min) mm	滚子 外径 Roller diameter D (max) mm	销轴 Pin			链板 Sidebar		最小抗拉 强度 Ultimate tensile strength Qmin kN	每米净重 Weight per meter q kg/m
				d mm	L <sub>1</sub> mm	L <sub>2</sub> mm	h mm	t/T mm		
SPN250A-SK <sub>2</sub> -2P	250	46	95	25	54.2	61.3	72	12	670	36.19
SPN250B-SK <sub>2</sub> -2P	250	42	80	24	52	60	60	12	520	26.79
SPN315A-SK <sub>2</sub> -2P	315	50	120	36	58.7	67.8	80	12	610	42.8