

模锻滑架
Forging Trolley

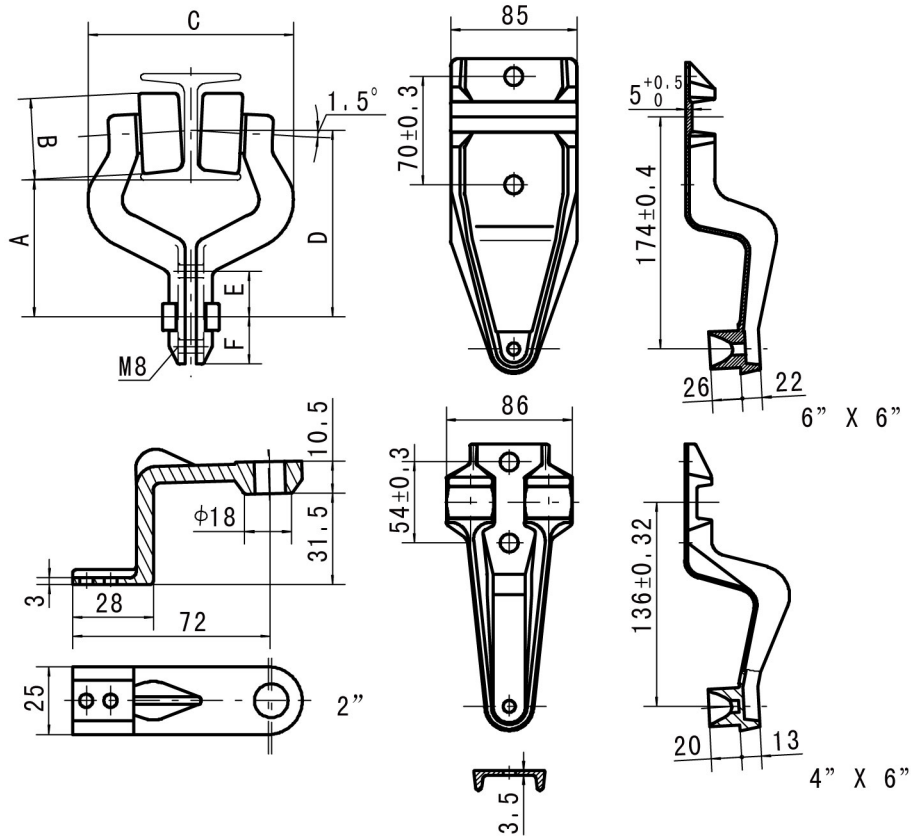

链号 Chain No.	参数 Dimensions							每节重量 Weight per meter kg/set
	A	B	C	D	E	F	G	
	mm	mm	mm	mm	mm	mm	mm	
348	64.0	60.0	100.0	100.0	25.5	22.5	16	1.35
458	82.0	80.0	136.0	128.6	33.5	20.5	20	2.70
678	89.0	82.0	144.0	136.0	31.0	23	16	3.45
CC100	82.0	82.0	136.0	128.6	25.5	22.5	18	2.70
160	101.6	120.0	170.0	170.0	42.0	28	20	7.50