



目录 CONTENTS

建筑行业用链

Building Industrial Chain

地面修整机链

Ground Finisher Chain..... 1

挖沟机链

Trencher Chains..... 2-5

地面修整机链 Ground Finisher Chain

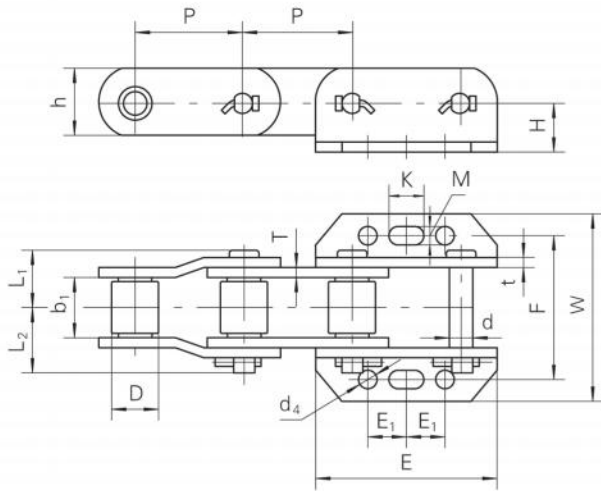

F	W	d ₄	M	K	E ₁	E	H
mm	mm	mm	mm	mm	mm	mm	mm
136.65	190.5	17.5	17.5	33.3	36.6	171.5	46

链号	节距	内节内宽	滚子外径	销轴			链板		最小抗拉强度
Chain No.	Pitch	Width between inner sidebars	Roller diameter	Pin			Sidebar		Ultimate tensile strength
	P	b ₁ (min)	D(max)	d	L ₁	L ₂	h	t/T	Fu(min)
	mm	mm	mm	mm	mm	mm	mm	mm	kN
HSR302-15	103.2	55.6	44.45	22.23	54.6	62.1	66.5	9.5	533.4

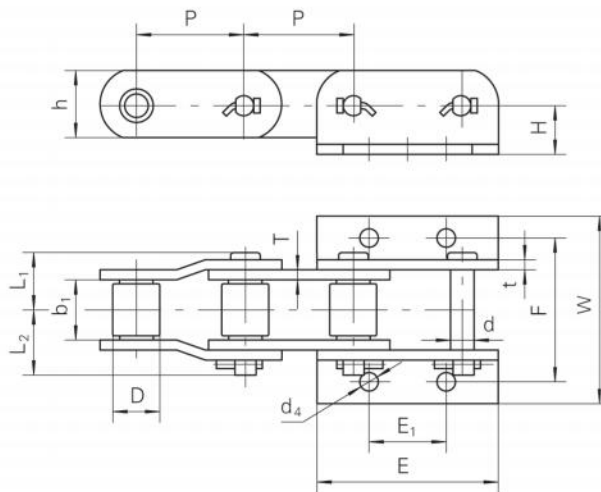

F	W	d ₄	E ₁	E	H
mm	mm	mm	mm	mm	mm
136.7	187.5	17.5	73.15	178	46

链号	节距	内节内宽	滚子外径	销轴			链板		最小抗拉强度
Chain No.	Pitch	Width between inner sidebars	Roller diameter	Pin			Sidebar		Ultimate tensile strength
	P	b ₁ (min)	D(max)	d	L ₁	L ₂	h	t/T	Fu(min)
	mm	mm	mm	mm	mm	mm	mm	mm	kN
HSR404-15	103.2	52.3	47.63	22.23	58.8	66.2	63.5	12.7	444.5

挖沟机链 Trencher Chains

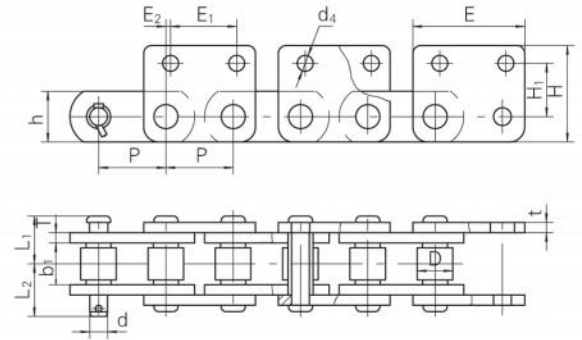
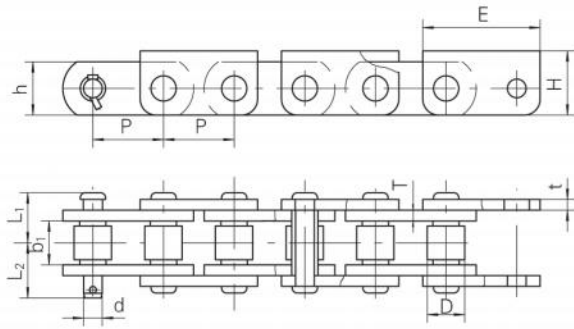

链号	H ₁	H	E	E ₁	E ₂	d ₄
Chain No.	mm	mm	mm	mm	mm	mm
2250GL-M	-	38.1	69.8	-	-	-
2250GL-M2	33.3	60.3	69.8	41.3	2.9	9.95
408LP	-	82.6	182.4	-	-	-

链号	节距	内节内宽	滚子直径	链板		销轴			最小抗拉强度	每米重量
				Sidebar		Pin				
				t/T	h	d	L ₁	L ₂		
Chain No.	Pitch	Width between inner sidebars	Roller diameter						Ultimate tensile strength	Weight per meter
	P	b _i (min)	D(max)							
	mm	mm	mm	mm	mm	mm	mm	mm	kN	kg/m
2250GL-M	42.01	25.2	22.23	4.9	31.8	11.1	26.9	29.4	120	6.57
2250GL-M2	42.01	25.2	22.23	6.4	31.8	11.1	29.9	33.9	120	9.47
408LP	103.78	40.5	44.45	12.7	76.2	22.23	53.9	61.3	450	31.9

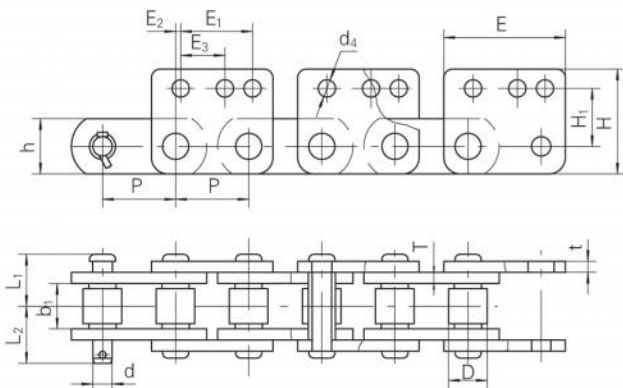

H ₁	H	E	E ₁	E ₂	E ₃	d ₄
mm	mm	mm	mm	mm	mm	mm
33.3	60.3	69.8	41.3	2.9	25.4	9.95

链号	节距	内节内宽	滚子直径	销轴			链板		最小抗拉强度	每米重量
				Pin			Sidebar			
				d	L ₁	L ₂	h	t/T		
Chain No.	Pitch	Width between inner sidebars	Roller diameter						Ultimate Tensile strength	Weight per meter
	P	b _i (min)	D(max)							
	mm	mm	mm	mm	mm	mm	mm	mm	kN	kg/m
2250GL-M3	42.01	25.2	22.23	11.1	26.9	29.4	31.8	4.9	120	7.78

挖沟机链 Trencher Chains

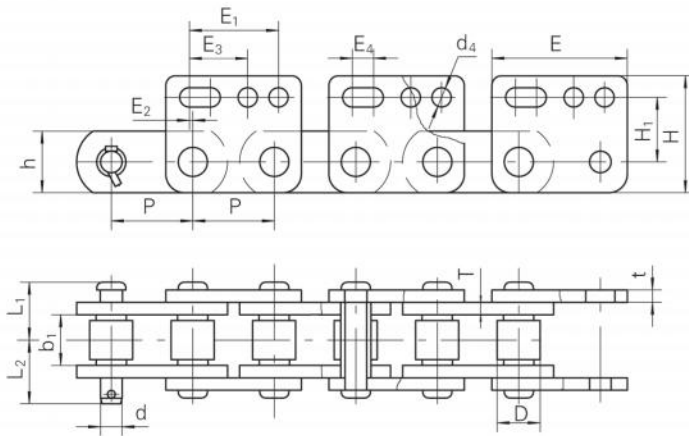

H ₁	H	E	E ₁	E ₂	E ₃	E ₄	d ₄
mm	mm	mm	mm	mm	mm	mm	mm
28.6	58.9	82.5	50.8	4.75	34.9	9.5	10.4

链号	节距	内节内宽	滚子直径	销轴			链板		最小抗拉强度	每米重量
Chain No.	Pitch	Width between Inner sidebars	Roller diameter	Pin			Sidebar		Ultimate tensile strength	Weight per meter
	P	b ₁ (min)	D(max)	d	L ₁	L ₂	h	t/T	Fu(min)	q
	mm	mm	mm	mm	mm	mm	mm	mm	kN	kg/m
165	42.01	25.2	22.23	11	29.1	25.2	35	6.4	133.4	10.41

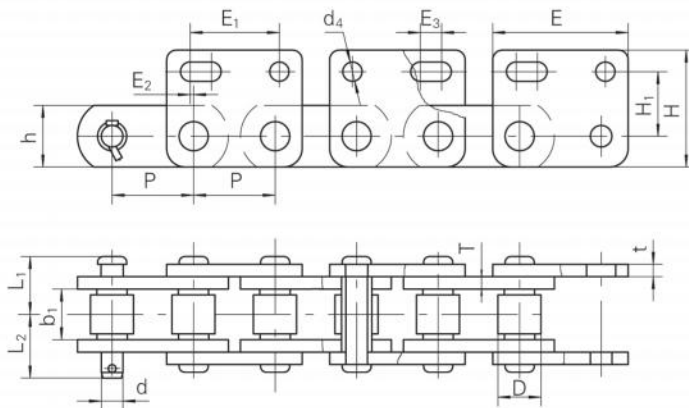

H ₁	H	E	E ₁	E ₂	E ₃	d ₄
mm	mm	mm	mm	mm	mm	mm
59.9	120.7	182.4	114.3	5.26	25.4	20.6

链号	节距	内节内宽	滚子直径	销轴			链板		最小抗拉强度	每米重量
Chain No.	Pitch	Width between inner sidebars	Roller diameter	Pin			Sidebar		Ultimate tensile strength	Weight per meter
	P	b ₁ (min)	D(max)	d	L ₁	L ₂	h	t/T	Fu(min)	q
	mm	mm	mm	mm	mm	mm	mm	mm	kN	kg/m
408	103.78	40.5	44.45	22.23	53.9	61.3	76.2	12.7	450	37.8

挖沟机链 Trencher Chains

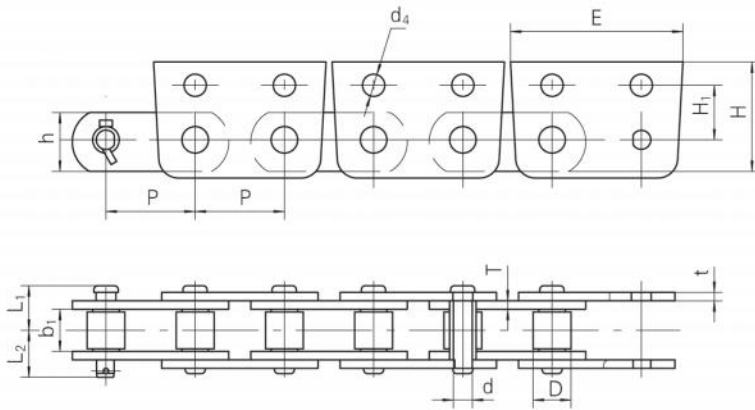

H ₁	H	E	d ₄
mm	mm	mm	mm
38.1	76.2	100	13.5

链号	节距	内节内宽	滚子直径	销轴			链板		最小抗拉强度	每米重量
Chain No.	Pitch	Width between inner sidebars	Roller diameter	Pin			Sidebar		Ultimate tensile strength	Weight per meter
	P	b ₁ (min)	D(max)	d	L ₁	L ₂	h	t/T	Fu(min)	q
	mm	mm	mm	mm	mm	mm	mm	mm	kN	kg/m
2.000	50.8	31.1	28.58	14.17	33.7	39.4	38.1	6.4	189	13.8

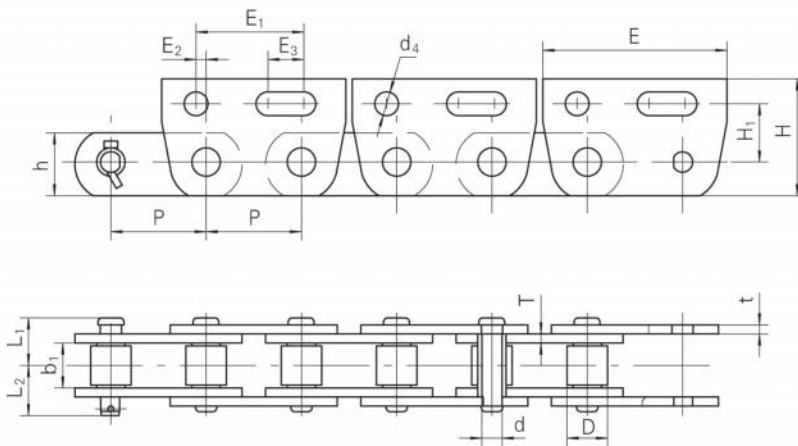

H ₁	H	E	E ₁	E ₂	E ₃	d ₄
mm	mm	mm	mm	mm	mm	mm
41.28	82.6	132	76.2	7.1	25.4	16.8

链号	节距	内节内宽	滚子直径	销轴			链板		最小抗拉强度	每米重量
Chain No.	Pitch	Width between inner sidebars	Roller diameter	Pin			Sidebar		Ultimate tensile strength	Weight per meter
	P	b ₁ (min)	D(max)	d	L ₁	L ₂	h	t/T	Fu(min)	q
	mm	mm	mm	mm	mm	mm	mm	mm	kN	kg/m
2600	67.31	31.1	28.58	14.27	33.7	39.4	44.5	6.4	189	13.1

挖沟机链 Trencher Chains

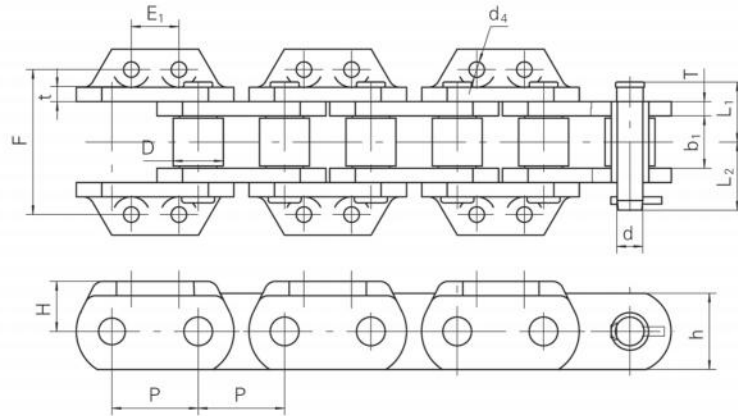

链号	节距	内节内宽	滚子直径	销轴			链板						最小抗拉强度	每米重量	
Chain No.	Pitch	Width between inner sidebars	Roller diameter	Pin			Sidebar						Ultimate tensile strength	Weight per meter	
				P	b ₁ (min)	D(max)	d	L ₁	L ₂	h	t/T	H			E ₁
	mm	mm	mm	mm	mm	mm	mm	mm	mm	mm	mm	mm	mm	mm	kN
2109	101.6	40.7	50.8	25.4	54.9	65.3	76.2	12.7	50.8	63.5	152.4	20.6	622	44.2	
4501	114.3	56.8	63.5	33.2	69.8	82.2	88.9	15.9	49.2	63.5	177.8	19.8	1100	56.6	
4501XHD	114.3	56.8	63.5	34.93	74.6	83.4	101.6	19.05	58.7	63.5	177.8	19.8	1150	73.8	
4550	114.3	68.7	63.5	33.2	75.8	88.2	88.9	15.9	57.2	63.5	190.5	19.8	1100	62.2	
4525	114.93	56.8	66.67	38.1	68.1	77	95.2	15.9	61	63.5	177.8	20.2	1350	66.6	
4525XHD	114.93	56.8	66.67	41.28	74.6	83.1	98.5	15.9/19.05	61	63.5	177.8	19.8	1420	77.1	
4555	114.93	69.5	66.67	38.1	77.7	86	95.2	15.9	61	63.5	192	20.6	1350	69.2	
P115.09	115.09	69.8	66.67	35	81.5	92.6	101.6	19.05	66.7	63.5	192.1	20.5	1150	80.0	
P167.38	167.38	87	98.43	54	95.8	105.9	139.7	19.05/22.23	82.6	76.2	231.8	26.2	2730	122.0	

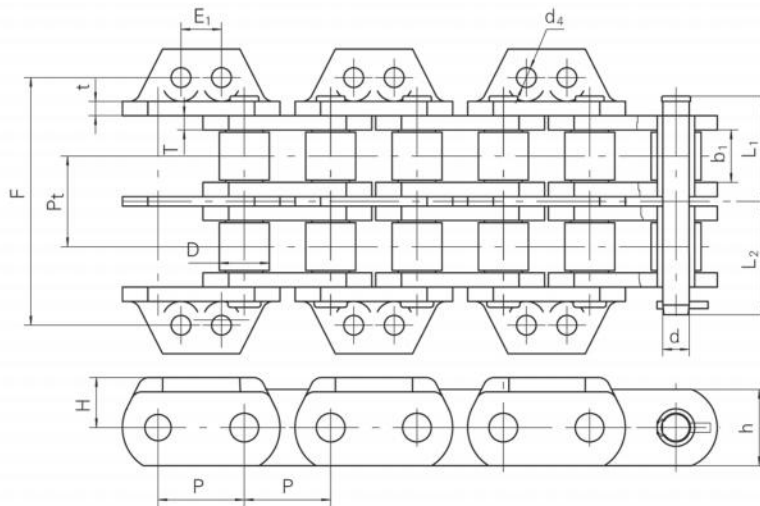

链号	节距	内节内宽	滚子直径	排距	销轴			链板						最小抗拉强度	每米重量
Chain No.	Pitch	Width between inner sidebars	Roller diameter	Pt	Pin			Sidebar						Ultimate tensile strength	Weight per meter
					d	L ₁	L ₂	h	t/T	H	E ₁	F	d ₄		
	mm	mm	mm	mm	mm	mm	mm	mm	mm	mm	mm	mm	mm	mm	kN
4502	114.3	56.8	63.5	107.95	33.2	123.7	136.1	88.9	15.9	49.2	63.5	284.2	19.8	2100	94.0
5503	115.09	69.8	66.67	122.24	35	142.2	157.1	101.6	19.05	66.7	54	330.2	26	2300	135.8