

## 刮板输送机链 Scraper Conveyor Chain

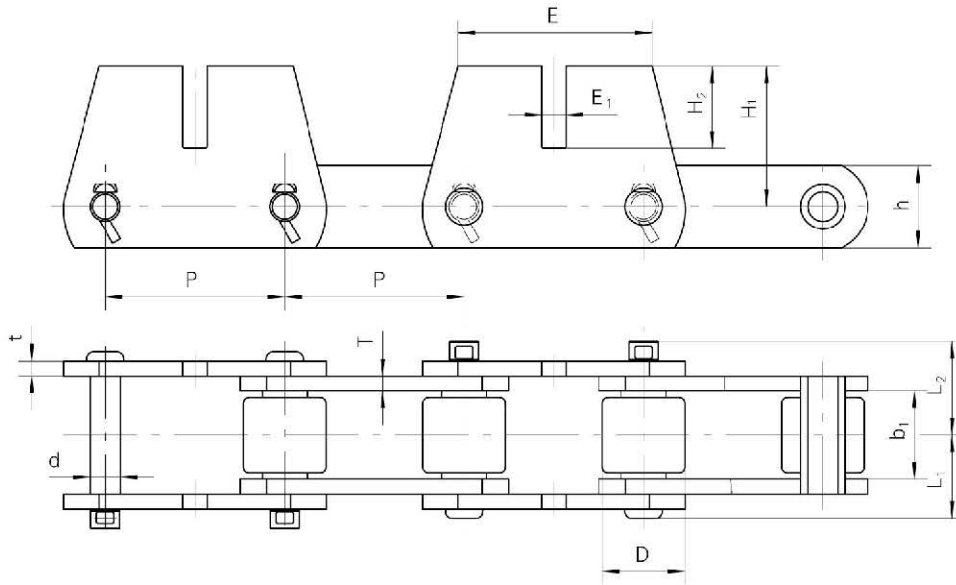

链号	H <sub>1</sub>	H <sub>2</sub>	E <sub>1</sub>	E
Chain No.	mm	mm	mm	mm
RC15517	63.55	33.55	12.5	88.9
RC15759	60.35	34.95	12.8	92
RC15491-M2	79.35	47.6	16.76	114.3
C9856-M2	117.47	69.84	20.6	165.1
9856-M2	117	85.7	20.6	167.8
RC15126	120.6b	/3	20.6	16b.1

链号	节距	内节内宽	滚子外径	销轴			链板		最小抗拉强度	每米重量
Chain No.	Pitch	Width between Inner sidebars	Roller diameter	Pin			Sidebar		Ultimate Tensile strength	Weight per meter
	P	b <sub>1</sub> (min)	D(max)	d	L <sub>1</sub>	L <sub>2</sub>	h	t/T	Fu(min)	q
	mm	mm	mm	mm	mm	mm	mm	mm	kN	kg/m
RC15517	78.1	37.8	31.75	15.88	44.5	48.9	38.1	9.5	266.7	13.52
RC15759	78.1	37.8	31.75	15.88	47.7	52.1	44.5	9.5/12.7	266.7	16.98
RC15491-M2	101.6	50.4	38.1	19.05	57.4	63.6	44.5	12.7	355.6	22.6
C9856-M2	152.4	74.93	69.85	25.3	72.6	82.3	69.85	12.7	622	44.35
9856-M2	152.4	76.2	69.85	25.4	73.4	80.6	70	12.7	622.3	44.8
RC15126	152.4	76.2	69.85	25.4	71.3	77.7	63.5	12.7	622.3	43.0

## 刮板输送机链 Scraper Conveyor Chain

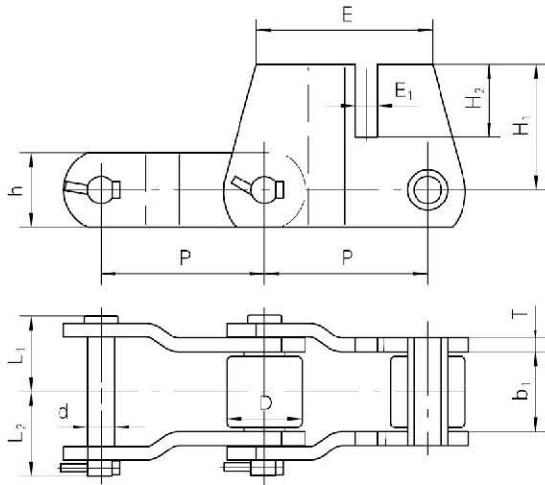

H <sub>1</sub>	H <sub>2</sub>	E <sub>1</sub>	E
mm	mm	mm	mm
117.47	69.84	20.6	165

链号	节距	内节内宽	滚子外径	销轴			链板		最小抗拉强度
Chain No.	Pitch	Width between inner sidebars	Roller diameter	Pin			Sidebar		Ultimate tensile strength
	P	b <sub>1</sub> (min)	D(max)	d	L <sub>1</sub>	L <sub>2</sub>	h	t/T	Fu(min)
	mm	mm	mm	mm	mm	mm	mm	mm	kN
R9856-M2	152.4	74.93	69.85	25.4	70.8	78.6	69.85	12.7	596

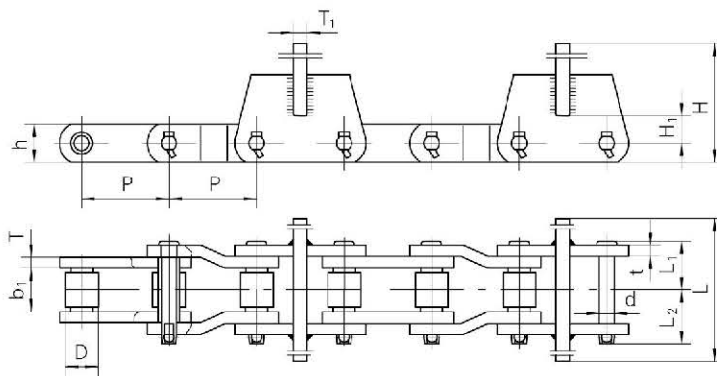

H	H <sub>1</sub>	T <sub>1</sub>	L
mm	mm	mm	mm
231.8	31.75	16	406.4

链号	节距	内节内宽	滚子外径	销轴			链板		最小抗拉强度	每米重量
Chain No.	Pitch	Width between inner sidebars	Roller diameter	Pin			Sidebar		Ultimate tensile strength	Weight per meter
	P	b <sub>1</sub> (min)	D(max)	d	L <sub>1</sub>	L <sub>2</sub>	h	t/T	Fu(min)	q
	mm	mm	mm	mm	mm	mm	mm	mm	kN	kg/m
RC15582	101.6	50.4	38.1	19.05	57.4	63.6	44.5	12.7	355.6	52.4

## 刮板输送机链 Scraper Conveyor Chain

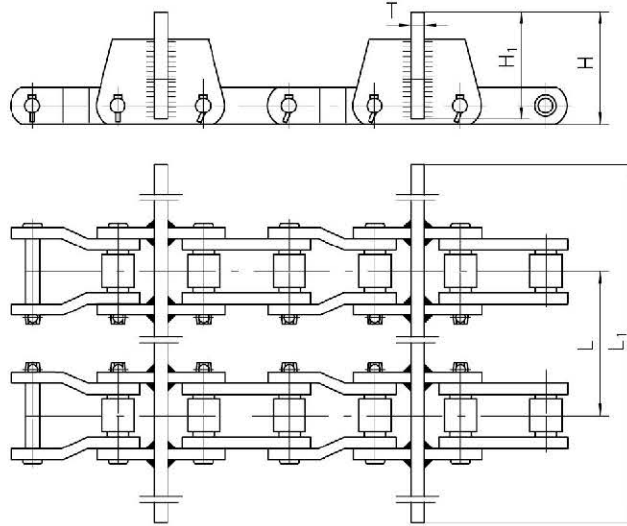

链号 Chain No.	T mm	H mm	H <sub>1</sub> mm	L mm	L <sub>1</sub> mm
ZRC15491-7-56	16	231.8	177.8	876.3	1422.4
ZRC15491-7-58	16	231.8	177.8	876.3	1473.2
ZRC15491-5-56	16	133.3	127	876.3	1428.8

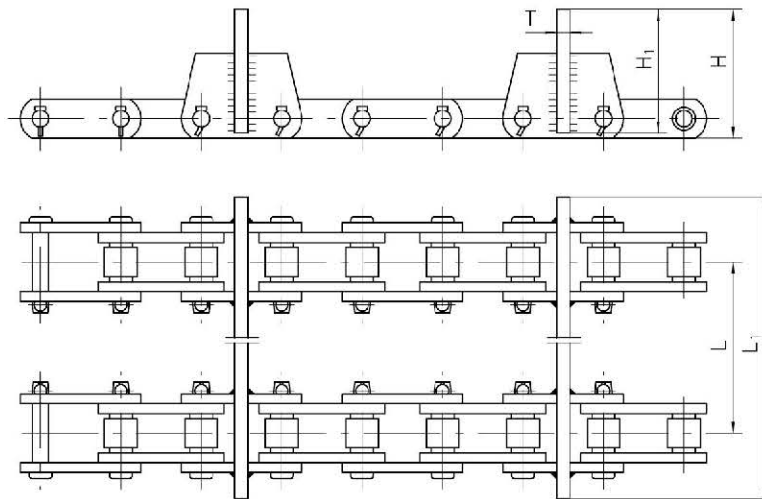

链号 Chain No.	T mm	H mm	H <sub>1</sub> mm	L mm	L <sub>1</sub> mm
ZRC15517	12	125.5	120.8	622.3	749.3
ZRC15759	12	127	120.7	622.3	762

## 刮板输送机链 Scraper Conveyor Chain

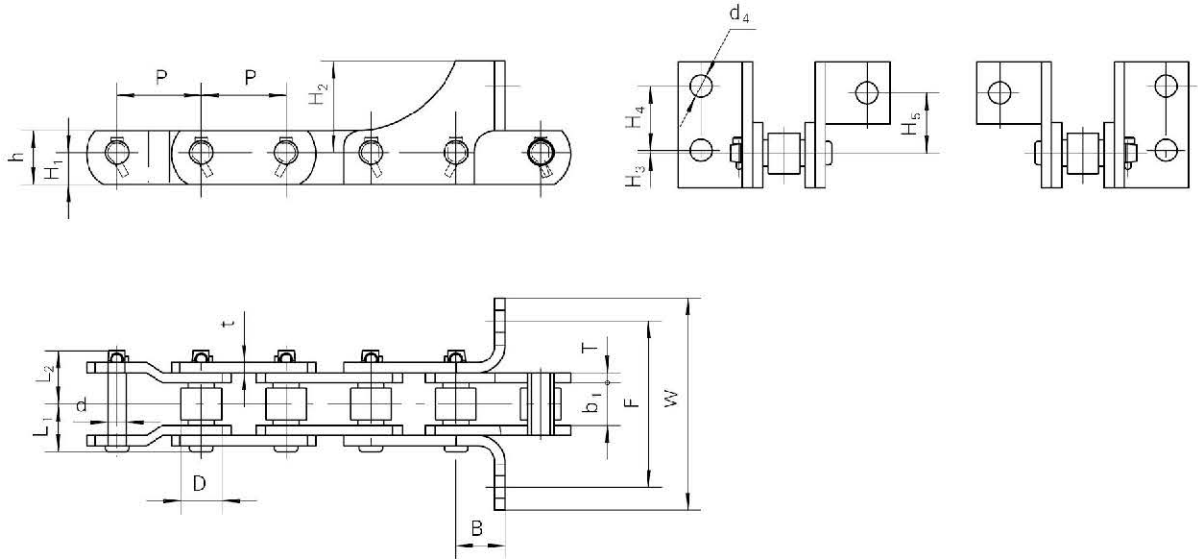

链号	H <sub>1</sub>	H <sub>2</sub>	H <sub>3</sub>	H <sub>4</sub>	H <sub>5</sub>	B	d <sub>4</sub>	F	W
Chain No.	mm	mm	mm	mm	mm	mm	mm	mm	mm
17790-73	30.2	81	1.6	60.3	49.2	45.2	20.6	157.1	192.4
17789-73	30.2	81	1.6	60.3	49.2	45.2	20.6	157.1	192.4
RC16149	30.2	81	1.6	60.3	49.2	45.2	20.6	155.6	203.2
RC16139	30.2	87.3	8	60.3	57.15	45.3	20.6	155.6	200

链号	节距	内节内宽	滚子外径	销轴			链板		最小抗拉强度
Chain No.	Pitch	Width between inner sidebars	Roller Diameter	Pin			Sidebar		Ultimate tensile strength
	P	b <sub>1</sub> (min)	D(max)	d	L <sub>1</sub>	L <sub>2</sub>	h	t/T	Fu(min)
	mm	mm	mm	mm	mm	mm	mm	mm	kN
17790-73	79	38.1	34.93	15.88	41.9	47	50.8	8	222.3
17789-73	79	38.1	34.93	15.88	41.9	47	50.8	8	222.3
RC16149	79	38.1	34.93	15.88	41.9	47	50.8	8	222.3
RC16139	79.5	37.9	38.1	17.48	44	50	57.15	9.5	203